

# BLUE STAR

## Power Systems Inc.

### Diesel Product Line

208-600 Volt

VD150-02FT4

60 Hz / 1800 RPM

150 kWe / 150 kWe

Standby / Prime

### Ratings

	240V	208V	240V	480V	600V
<b>Phase</b>	1	3	3	3	3
<b>PF</b>	1.0	0.8	0.8	0.8	0.8
<b>Hz</b>	60	60	60	60	60
<b>Generator Model</b>	431CSL6206	431CSL6204	431CSL6204	431CSL6204	431PSL6242
<b>Connection</b>	12 LEAD ZIG-ZAG	12 LEAD WYE	12 LEAD DELTA	12 LEAD WYE	4 LEAD WYE
<b>Standby</b>					
<b>kWe</b>	150	150	150	150	150
<b>AMPS</b>	625	521	452	226	181
<b>Temp Rise</b>	105°C / 40°C	105°C / 40°C	105°C / 40°C	105°C / 40°C	105°C / 40°C
<b>Prime</b>					
<b>kWe</b>	150	150	150	150	150
<b>AMPS</b>	625	521	452	226	181
<b>Temp Rise</b>	105°C / 40°C	105°C / 40°C	105°C / 40°C	105°C / 40°C	105°C / 40°C

### Standard Equipment

- |   |  |   |
|---|--|---|
| <p><b>Engine</b></p> <ul style="list-style-type: none"> <li>▶ Radiator Cooled Unit Mounted (55°C)</li> <li>▶ Blower Fan &amp; Fan Drive</li> <li>▶ Starter &amp; Alternator</li> <li>▶ Oil Pump &amp; Filter</li> <li>▶ Oil Drain Extension w/Valve</li> <li>▶ Governor - Electronic Isochronous</li> <li>▶ 24V Battery System &amp; Cables</li> <li>▶ Air Cleaner (Dry Single Stage)</li> <li>▶ Flexible Fuel Connector</li> <li>▶ EPA Certified Tier 4 Final</li> </ul> <p><b>Listing Certifications</b></p> <ul style="list-style-type: none"> <li>▶ UL 2200 Listed</li> <li>▶ cUL Listed</li> <li>▶ CSA Certified</li> <li>▶ Seismic Certified to IBC 2018</li> <li>▶ NFPA 110 Compliant</li> </ul> | <p><b>Generator</b></p> <ul style="list-style-type: none"> <li>▶ Brushless Single Bearing</li> <li>▶ Automatic Voltage Regulator</li> <li>▶ ± 1% Voltage Regulation</li> <li>▶ 4 Pole, Rotating Field</li> <li>▶ 105°C Standby Temperature Rise</li> <li>▶ 105°C Prime Temperature Rise</li> <li>▶ 100% of Rated Load - One Step</li> <li>▶ 5% Maximum Harmonic Content</li> <li>▶ NEMA MG 1, IEEE and ANSI Standards Compliance for Temperature Rise</li> </ul> | <p><b>Additional</b></p> <ul style="list-style-type: none"> <li>▶ Single Source Supplier</li> <li>▶ Microprocessor Based Digital Control</li> <li>▶ Interface Connection Box</li> <li>▶ Control Panel Mounted in NEMA 12 Enclosure</li> <li>▶ Base - Formed Steel</li> <li>▶ Main Line Circuit Breaker Mounted &amp; Wired</li> <li>▶ SCR Catalyst / Silencer Mounted</li> <li>▶ Battery Charger 24V 5 Amp</li> <li>▶ Jacket Water Heater -20°F 2500W 240V w/Isolation Valves</li> <li>▶ Vibration Isolation Mounts</li> <li>▶ Radiator Duct Flange (OPU Only)</li> <li>▶ 2YR / 2000HR Standby Warranty</li> <li>▶ 1YR / 1500HR Prime Warranty</li> <li>▶ Standard Colors - White / Gray</li> </ul> |
|---|--|---|

## Application Data

Engine		
Manufacturer:	Volvo Penta	Displacement - Cu. In. (lit): 470 (7.70)
Model:	TAD871VE	Bore - in. (cm) x Stroke - in. (cm): 4.33(11.0) x 5.31 (13.5)
Type:	4-Cycle	Compression Ratio: 17.5:1
Aspiration:	Turbo Charged, CAC	Rated RPM: 1800
Cylinder Arrangement:	6 Cylinder Inline	Max HP Stby (kWm): 252 (185)

Exhaust System	Standby	Prime
Gas Temp. (Stack): °F (°C)	709 (376)	709 (376)
Gas Volume at Stack Temp: CFM (m³/min)	886 (25.1)	886 (25.1)
Maximum Allowable Exhaust Restriction (Post SCR Cat.): in. H <sub>2</sub> O (kPa)	24.0 (6.00)	24.0 (6.00)
Cooling System		
Ambient Capacity of Radiator: °F (°C)	131 (55.0)	131 (55.0)
Maximum Allowable Static Pressure on Rad. Exhaust: in. H <sub>2</sub> O (kPa)	0.50 (0.12)	0.50 (0.12)
Water Pump Flow Rate: GPM (lit/min)	102 (386)	102 (386)
Heat Rejection to Coolant: BTUM (kW)	6,995 (122)	6,995 (122)
Heat Rejection to CAC: BTUM (kW)	1,666 (29.3)	1,666 (29.3)
Heat Radiated to Ambient: BTUM (kW)	2,135 (37.4)	2,135 (37.4)
Air Requirements		
Aspirating: CFM (m³/min)	445 (12.6)	445 (12.6)
Air Flow Required for Rad. Cooled Unit: CFM (m³/min)	16,961 (480)	16,961 (480)
Air Flow Required for Heat Exchanger/Rem. Rad. CFM (m³/min)	Consult Factory For Remote Cooled Applications	
Fuel Consumption		
At 100% of Power Rating: gal/hr (lit/hr)	10.6 (40.0)	10.6 (40.0)
At 75% of Power Rating: gal/hr (lit/hr)	8.50 (32.0)	8.50 (32.0)
At 50% of Power Rating: gal/hr (lit/hr)	6.08 (23.0)	6.08 (23.0)
DEF Consumption (% of fuel consumption)	± 7.00%	± 7.00%
Fluids Capacity		
Total Oil System: gal (lit)	7.13 (27.0)	7.13 (27.0)
Engine Jacket Water Capacity: gal (lit)	4.50 (17.0)	4.50 (17.0)
System Coolant Capacity: gal (lit)	13.5 (51.1)	13.5 (51.1)
DEF Tank Capacity: gal (lit)	18.5 (70.0)	18.5 (70.0)

Deration Factors

Rated Power is available up to 4,921 Ft (1500m) at ambient temperatures to 122°F (50°C) standby and prime. Consult factory for site conditions above these parameters.

## DGC-2020 Control Panel

### Standard Features

- ▶ Digital Metering
- ▶ Engine Parameters
- ▶ Generator Protection Functions
- ▶ Engine Protection
- ▶ CAN Bus (J1939) ECU Communications
- ▶ Windows-Based Software
- ▶ Multilingual Capability
- ▶ Remote Communications to RDP-110 Remote Annunciator
- ▶ 16 Programmable Contact Inputs
- ▶ 15 Contact Outputs
- ▶ RS485 Communicator Interface
- ▶ UL Recognized, CSA Certified, CE Approved
- ▶ Event Recording
- ▶ IP 54 Front Panel Rating with Integrated Gasket
- ▶ NFPA 110 Level 1 Compatible

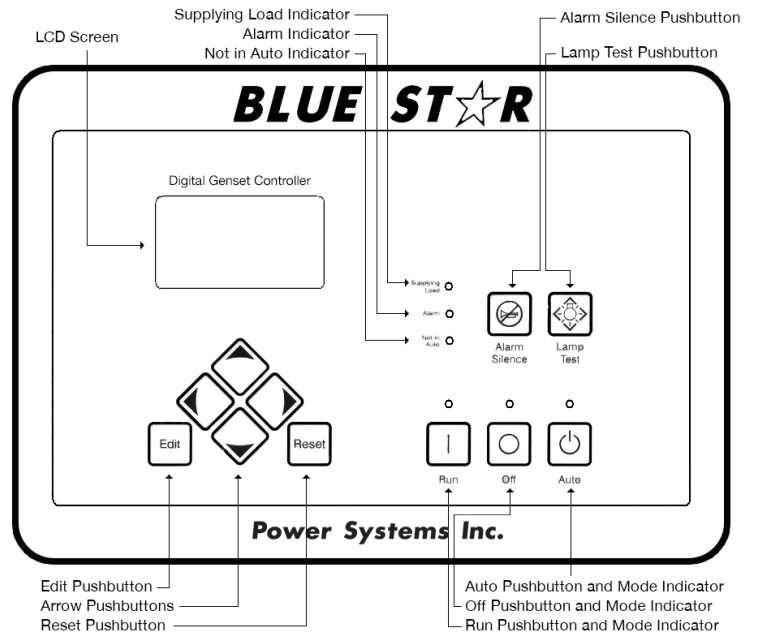

## Weights / Dimensions / Sound Data

	L x W x H	Weight lbs
<b>OPU</b>	110 x 60 x 75 in	4,525
<b>Level 1</b>	134 x 60 x 82 in	5,450
<b>Level 2</b>	134 x 60 x 82 in	5,500
<b>Level 3</b>	174 x 60 x 82 in	5,775

Please allow 6-12 inches for height of exhaust stack.

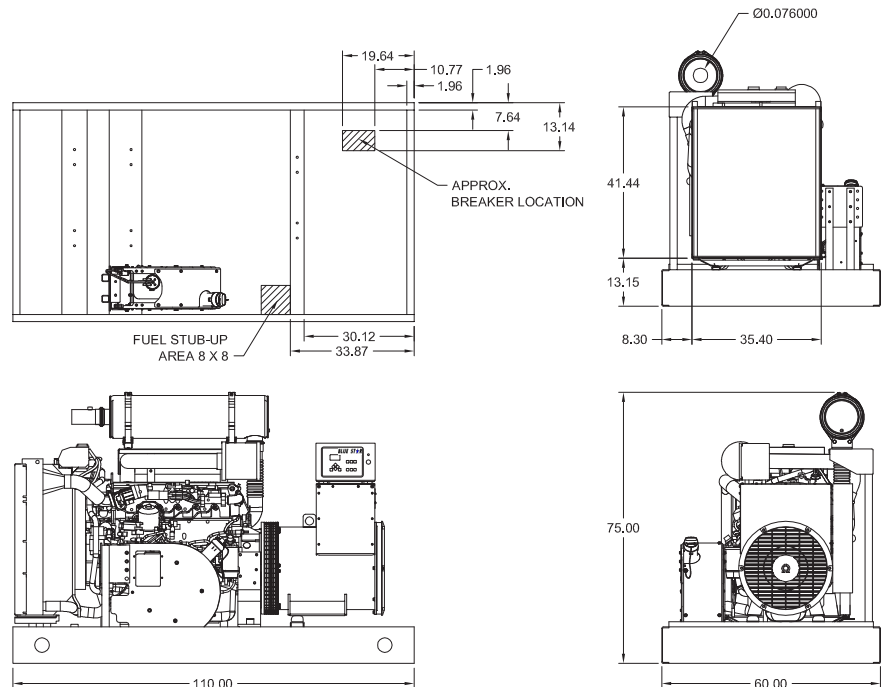

Drawings based on standard open power 480 volt standby generator. Lengths may vary with other voltages. Subject to change without notice. Sound data as measured at 23 feet (7 meters) in accordance with ISO 8528-10 at standby rating.

# Diesel Product Line

150 kW / 150 kWe



## Enclosures & Fuel Tanks

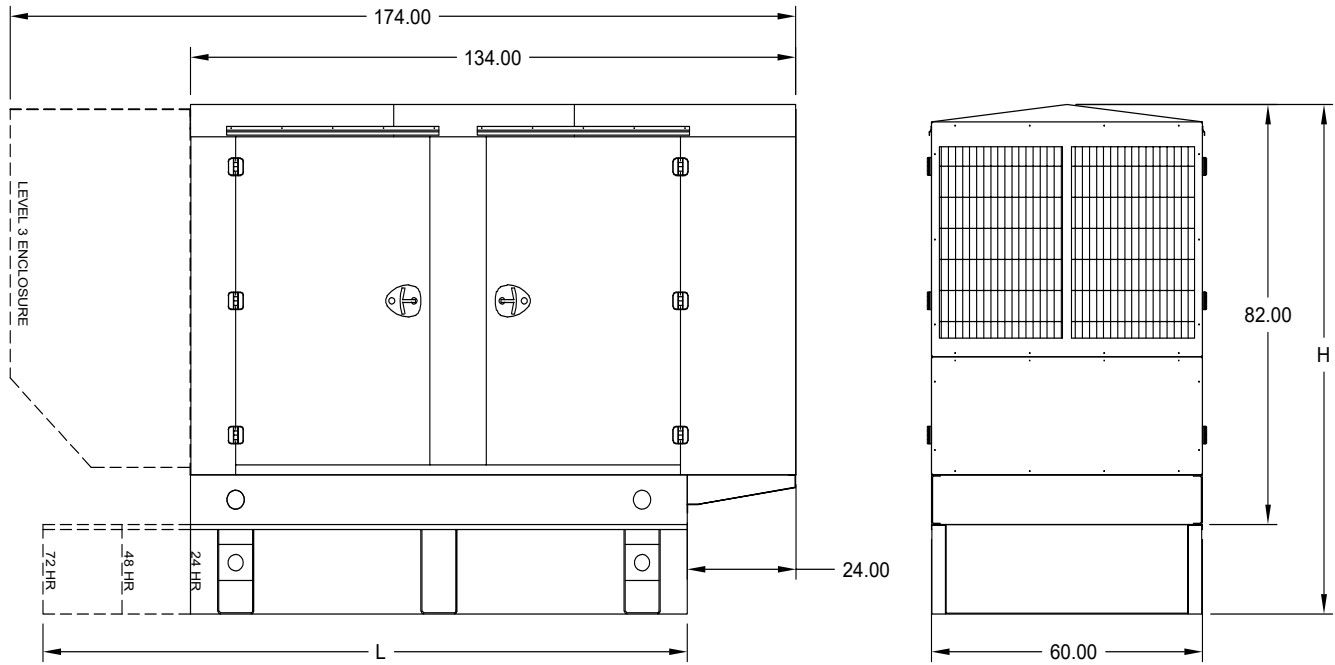

All enclosure models are 200 MPH wind rating certified in accordance with IBC2018 and ASCE/SEI 7-16 standards.

Level 2 & 3 enclosures include sound attenuation foam.

Level 3 enclosure includes frontal sound & exhaust hood.

\*Enclosure height does not include exhaust stack.

	24 Hour 375 Gallon	48 Hour 750 Gallon	72 Hour 1125 Gallon
<b>L</b>	110.00	120.00	168.00
<b>H</b>	104.00	118.00	118.00

All specification sheet dimensions are represented in inches.

All enclosures and fuel tanks are based on the standard standby unit configuration. Any deviation can change dimensions.

Materials and specifications subject to change without notice.

American Owned



American Made

Distributed By:

**Blue Star Power Systems, Inc.**

2250 Carlson Drive

North Mankato, Minnesota 56003

Phone + 1 507 345 1776

bluestarps.com

quote.bluestarps.com

sales@bluestarps.com